

MMPX 303SGP-11

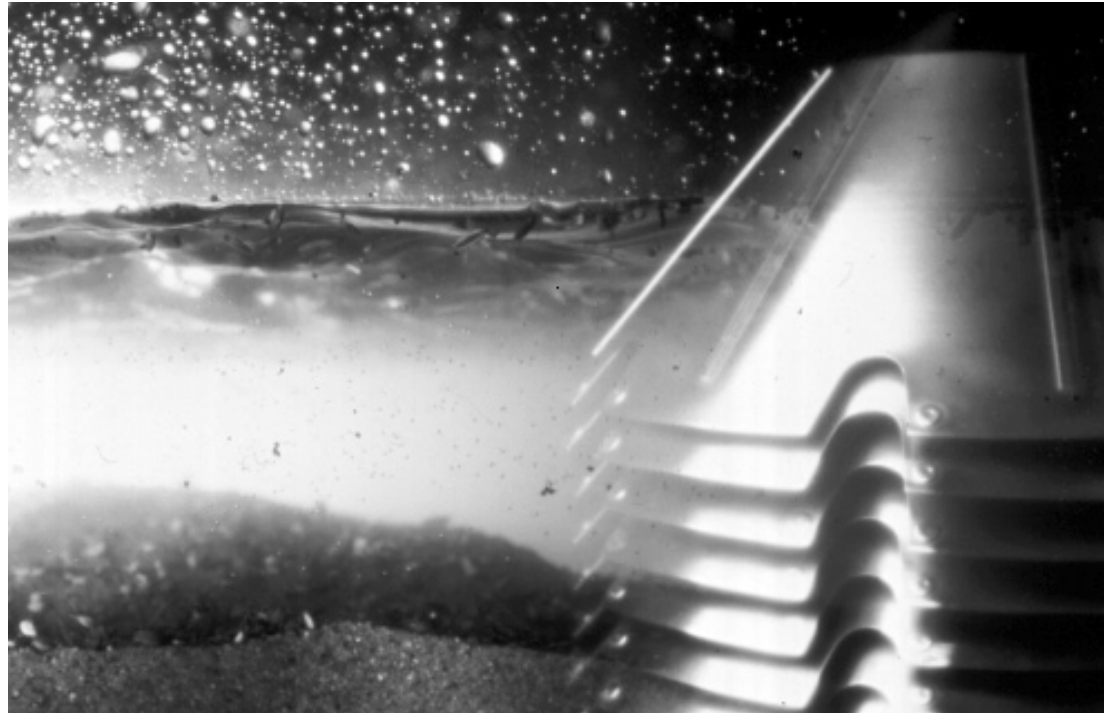

Spare parts catalogue

Reservdelskatalog

Ersatzteilkatalog

Catalogue de pièces de
rechange

Catalogue de piezas de
recambio

Каталог запасных
частей

Catalogo parti di ricambio

Catalogo de pecas
sobressalentes

Varaosaluettelo

Καταλογος
ανταλλακτικων

Reserveonderdelen-
catalogus

Reservdelskatalog

Alfa Laval Separation AB
Separator Manuals, dept. SKEL
S-147 80 Tumba, Sweden

Telephone: +46 8 53 06 50 00
Telefax: +46 8 53 03 10 40

Printed in Sweden, 99-11

© **Alfa Laval Separation AB 1999**

This publication or any part thereof may not be reproduced or transmitted by any process or means without prior written permission of Alfa Laval Separation AB.

Contents

1	Read this first	5
2	Machine bottom part	12
2.1	Oil filling device	20
2.2	Belt tightener	22
2.3	Friction coupling	24
3	Separator bowl	26
4	Frame hood with inlet and outlet	28
5	Parts for mounting of motor 60 Hz	30
5.1	Friction coupling	32
6	Gravity disc for clarification	34
7	Set of tools	36
8	Intermediate service kit	38
9	Major service kit	40
10	Tool box	42
11	Cross reference list	45

1 Read this first



- en** Check the machine unit number on the name-plate before using this catalogue
- sv** Kontrollera maskinenhetens nummer på maskinskytten innan du använder katalogen
- de** Das Typenschild - ein Hinweis zur korrekten Ersatzteilnummer
- fr** La plaque de la machine, un guide pour trouver le numéro de pièce de rechange correct
- es** La placa-marca de la máquina - guía del número correcto del repuesto
- ru** Фирменная табличка машины – указатель правильного номера запасной части
- it** La targhetta della macchina - guida al corretto numero dei ricambi
- pt** A placa do fabricante da máquina - um guia do número correto das partes sobressalentes
- fi** Konekilpi - opastin oikeaan varaosnumeroon
- el** Η πινακίδα της μηχανής είναι ο οδηγός του σωστού ανταλλακτικού
- nl** Het gegevensplaatje - een wegwijzer naar het juiste onderdeelnummer
- da** Typeskiltet - en guide til det rette reservedelsnummer

en

Safeguard your commitment to quality by always using genuine Alfa Laval spare parts.

Remember, Alfa Laval cannot accept responsibility for the failure of a separator equipped with non-original spare parts. We guarantee the quality and reliability of our products.

sv

Följ ditt kvalitetstänkande genom att endast använda Alfa Laval originalreservdelar.

Kom ihåg att Alfa Laval inte tar något ansvar för fel på en separator, som innehåller icke-originaldelar. Vi garanterar kvaliteten och driftsäkerheten endast hos våra egna produkter.

de

Aus Rücksicht auf Ihr Bestreben um beste Qualität sollten Sie nur Alfa Laval Originalersatzteile benutzen.

Vergessen Sie nicht, Alfa Laval kann keine Verantwortung für das Versagen eines Separators übernehmen, der nicht mit Originalersatzteilen versehen ist. Wir garantieren Qualität und Zuverlässigkeit unserer Produkte.

fr

Préservez la qualité de vos équipements en n'employant que des pièces de rechange Alfa Laval.

N'oubliez pas q'Alfa Laval décline toute responsabilité en cas de panne d'un séparateur non équipé de pièces de rechange d'origine. Nous garantissons la qualité et la fiabilité de nos produits.

es

Mantenga su compromiso con la calidad, al usar siempre piezas de repuesto Alfa Laval auténticas.

Recuerde que Alfa Laval no acepta responsabilidad por el fallo de una separadora equipada con piezas de repuesto no originales. Garantizamos la calidad y fiabilidad de nuestros productos.



50023621

ru

Гарантируйте надежность качества всегда используя подлинные запасные части фирмы Alfa Laval.

Запомните, что Alfa Laval не несет ответственности за повреждение сепаратора, оснащенного неподлинными запчастями. Мы гарантируем качество и надежность наших изделий.

it

Salvaguardate la vostra garanzia di qualità facendo sempre uso di parti di ricambio Alfa Laval autentiche.

Tenete presente che la Alfa Laval non può accettare responsabilità per avaria ad un separatore attrezzato con parti di ricambio non originali. Noi garantiamo la qualità l'affidabilità dei nostri prodotti.

pt

Proteja o seu cometimento a qualidade usando sempre peças sobressalentes genuinas Alfa Laval.

Não esqueça que Alfa Laval não aceita responsabilidade por falha de uma separadora equipada com peças sobressalentes não genuinas. Nós garantimos a qualidade e a confiança dos nossos produtos.

fi

Varmistakaa vastuunne laadusta käyttämällä aina alkuperäisiä Alfa Laval varaosia.

Muistakaa, Alfa Laval ei voi hyväksyä vastuuta ei-alkuperäisillä varaosilla varustetun separaattorin vaurioista. Me takaamme tuotteidemme laadun ja käyttövarmuuden.

el

Εξασφαλίστε υψηλή ποιότητα χρησιμοποιώντας μόνο γνήσια ανταλλακτικά της Alfa Laval.

Έχετε υπόψη ότι η Alfa Laval δεν αναλαμβάνει καμμία ευθύνη για βλάβες βουτυρομηχανής, στην οποία έχουν εφαρμοστεί μη γνήσια ανταλλακτικά. Εγγυόμαστε ποιότητα και καλή λειτουργία μόνο για τα δικά μας προϊόντα.



nl

Streef naar een zo hoog mogelijke kwaliteit en gebruik uitsluitend originele Alfa Laval reserveonderdelen. Streef naar een zo hoog mogelijke kwaliteit en gebruik uitsluitend originele Alfa Laval reserveonderdelen.

Vergeet niet dat Alfa Laval niet verantwoordelijk is voor een defecte separator die niet-originele onderdelen bevat. Wij garanderen de kwaliteit en betrouwbaarheid van onze eigen producten.

da

Hold Dem til den kvalitet, De har valgt at satse på, ved altid at anvende ægte Alfa Laval reservedele.

Husk, at Alfa Laval ikke kan påtage sig noget ansvar for fejl på en separator, som indeholder uoriginale dele. Vi kan kun garantere kvalitet og driftsikkerhed på vore egne produkter.



50023621

Translation list

Översättningslista
 Übersetzungsliste
 Liste de traduction
 Lista de traducciones

en	sv	de	fr	es
Part no.	Reservdelsnummer	Teil-Nr.	Numéro de pièce	Pieza No.
Qty	Antal	Anzahl	Quantité	Cantidad
Description	Benämning	Bezeichnung	Dénomination	Descripción
Notes	Anmärkning	Anmerkungen	Remarques	Notas
Machine type	Maskintyp	Maschinentyp	Type de machine	Tipo de máquina
Product no.	Produktnr	Produktnummer	Numéro de produit	Número de producto
Machine unit description	Maskinblocksbenämning	Bezeichnung des Maschinenblocks	Dénomination de partie de machine	Descripción de sección de la máquina
Machine unit no.	Maskinblocksnr	Maschinenblock Nr.	Partie de machine n°	No. de sección de máquina
Subassembly description	Undergruppsbenämning	Bezeichnung der Untergruppe	Dénomination de sous-ensemble	Descripción de subconjunto
Subassembly no.	Undergruppsnr	Untergruppe Nr.	N° de sous-ensemble	Número de subconjunto
See page	Se sidan	Siehe Seite	Voir page	Véase la página
Fig. ref.	Figurhänvisning	Bildhinweise	Réf. de fig.	Referencia de figura
Product name	Produktnamn	Produktname	Nom du produit	Nombre del producto
Exchange necessitates rebalancing of bowl	Utbyte nödvändiggör ombalansering av kulan	Austausch erfordert Wiederauswuchtung der Trommel	Le remplacement nécessite le rééquilibrage du bol	El racmbio requiere el reequilibrado del rotor
See separate spare parts list	Se separat reservdelslista	Siehe separate Ersatzteilliste	Voir liste séparée des pièces de rechange	Véase la lista de piezas separada
Not delivered as spare part	Levereras ej som reservdel	Nicht als Ersatzteil geliefert	Non livré comme pièce de rechange	No se entrega como pieza de recambio

Translation list

Словарь перевода
 Lista traduzioni
 Lista para tradução
 Käännösluttelo

en	ru	it	pt	fi
Part no.	Деталь №	Nr.parte.	Numero de peca	Varaosanumero
Qty	Кол-во	Quantita	Quantidade	Lukumäärä
Description	Наименование	Descrizione	Descricao	Nimitys
Notes	Примечания	Note	Notas	Huomatuksia
Machine type	Машина тпа	Tipo macchina	Tipo de maquina	Konetyyppi
Product no.	Артикул №	Nr.prodotto	No. do produto	Tuotteen no
Machine unit description	Наименование блока машины	Nr. unita macchina	Descricao da unidade da maquina	Koneenosan nimitys
Machine unit no.	Блок машины №	Descrizione sottogruppo	Numero de unidade da maquina	Koneenosan no
Subassembly description	Наименование группы	Descrizione unita macchina	Descricao do subconjunto	Alaryhmän nimitys
Subassembly no.	Группа №	Nr. sottogruppo.	Número de subconjunto	Alaryhmän no
See page	См. страницу	Vedi pagina	Véase la página	Ks sivu
Fig. ref.	Ссылка на эскиз	Rif. fig.	Referencia de figura	Kuvaviite
Product name	Наименование артикула	Nome prodotto	Nombre del producto	Tuotteen nimi
Exchange necessitates rebalancing of bowl	Замена требует балансировки барабана	La sostituzione comporta la iequilibratura del tamburo	El racmbio requiere el reequilibrado del rotor	Vaihdettaessa kuula tasapainoitettava uudelleen
See separate spare parts list	См. отдельный перечень запасных частей	Vedi lista separata delle parti di ricambio	Véase la lista de piezas separada	Katso erillistä varaosaluettelo
Not delivered as spare part	Не поставлена вместе с запасными частями	Non fornito come parte di ricambio	No se entrega como pieza de recambio	Ei toimiteta varaosana

Translation list

ΓΛΩΣΣΑΡΙ
Vertaallijst
Oversættelsesliste

en	el	nl	da
Part no.	Αριθμός ανταλλακτικού	Onderdeelnr.	Reservedelsnummer
Qty	Σύνολο	Hoeveelheid	Antal
Description	Περιγραφή	Beschrijving	Betegnelse
Notes	Παρατηρήσεις	Opmerkingen	Bemaerkninger
Machine type	Τύπος μηχανήματος	Machinetype	Maskintype
Product no.	Αριθμός προϊόντος	Produktnr.	Produktnr.
Machine unit description	Περιγραφή συγκροτήματος μηχανής	Machineblokbenaming	Maskinbetegnelse
Machine unit no.	Αριθμός συγκροτήματος μηχανής	Machineblokbenaming	Maskinnr.
Subassembly description	Περιγραφή υποσυγκροτήματος	Subgroepbenaming	Undergruppsbetegnelse
Subassembly no.	Αριθμός υποσυγκροτήματος	Subgroepnr.	Undergruppenr.
See page	Βλέπε σελίδα	Zie blz.	Se side
Fig. ref.	Παραπομπή σε εικόνα	Afb. ref.	Figurhenviisning
Product name	Ονομασία προϊόντος	Produktnaam	Produktnavn
Exchange necessitates rebalancing of bowl	Ανταλλαγή απαιτεί επαναρρύθμιση ισορροπίας του τύμπανου	Vervanging vereist herbalanceren van de kogel	Udskriftning kraever ny afbalcering af kuglen
See separate spare parts list	Βλέπε ειδική λίστα ανταλλακτικών	Vervanging vereist van de kogel	Se spaat reservedelsliste
Not delivered as spare part	Δεν παραδίδεται ως ανταλλακτικό	Niet geleverd als reserveonderdeel	Levereres ikke som reservedel

2 Machine bottom part

Ref	Part No	Description	Machine unit number or Subassembly description 548009-						Notes
			-06	-07	-08	Quantity			
		50 Hz	↓						
		60 Hz		↓					
		60 Hz intended for NEMA standard			↓				
1	548010 02	Frame bottom part	1	1	1				
2	545892 01	Frame foot	4	4	4				
3	223107 35	Spring washer	4	4	4				
4	221045 29	Screw	4	4	4				
5	545735 02	Water container	1	1	1				
6	221040 25	Screw	2	2	2				
7	546563 01	O-ring	1	1	1				
8	548550 80	Cover with overflow pipe	1	1	1				
8 A	548494 80	Cover	1	1	1				
8 B	548543 80	Pipe	1	1	1				
8 C	539418 05	Elbow coupling	1	1	1				
8 D	528920 04	Hose nipple	2	2	2				
8 E	548612 01	Pipe	1	1	1				
8 F	526371 03	Elbow	1	1	1				
9	221040 25	Screw	2	2	2				
10	545831 80	Oil filling device	1	1	1				See page 20
11	548012 02	Frame intermediate part	1	1	1				
12	68956	Hose nipple	1	1	1				
13	223412 38	O-ring	1	1	1				
14	223412 49	O-ring	1	1	1				
15	548152 03	Washer	6	6	6				
16	221040 05	Screw	6	6	6				
17	543619 80	Rubber buffer	2	2	2				
18	545600 01	Bowl spindle	1	1	1				
19	548051 05	Ball bearing	1	1	1				
20	37535	Ball bearing	1	1	1				
21	545601 80	Oil pump	1	1	1				
22	545596 01	Belt pulley	1	1	1				
23	223406 25	O-ring	1	1	1				
24	545597 01	Wing	1	1	1				
25	545599 80	Pump sleeve	1	1	1				
26	543609 02	Ball bearing holder	1	1	1				
27	223642 36	Snap ring	1	1	1				
28	545620 02	Buffer holder	1	1	1				
29	544203 02	Fan	1	1	1				
30	543612 01	Gasket	1	1	1				
31	543613 02	Top bearing cover	1	1	1				
32	221035 02	Screw	6	6	6				
33	544337 02	Deflector ring	1	1	1				
34	223406 29	O-ring	1	1	1				
35	545782 02	Motor adapter	1	1					
36	545856 80	Belt tightener	1	1					See page 22
36	545856 81	Belt tightener			1				See page 22
37	548152 03	Washer	4	4					
38	221040 52	Screw	4	4					
39	544575 80	Friction coupling	1						See page 24
39	544575 81	Friction coupling		1					See page 24
40	543669 01	Washer	1	1					
41	70915	Spring washer	1	1					
42	221035 08	Screw	1						
42	221035 12	Screw		1					
43	548152 03	Washer	4	4					
44	221040 05	Screw	4	4					
45	260169 22	Flat belt	1						
45	260169 23	Flat belt		1					
46	544923 02	Frame top part	1	1	1				
47	539418 03	Elbow	1	1	1				
48	68956	Hose nipple	1	1	1				
49.1	528920 04	Hose nipple	1	1	1				

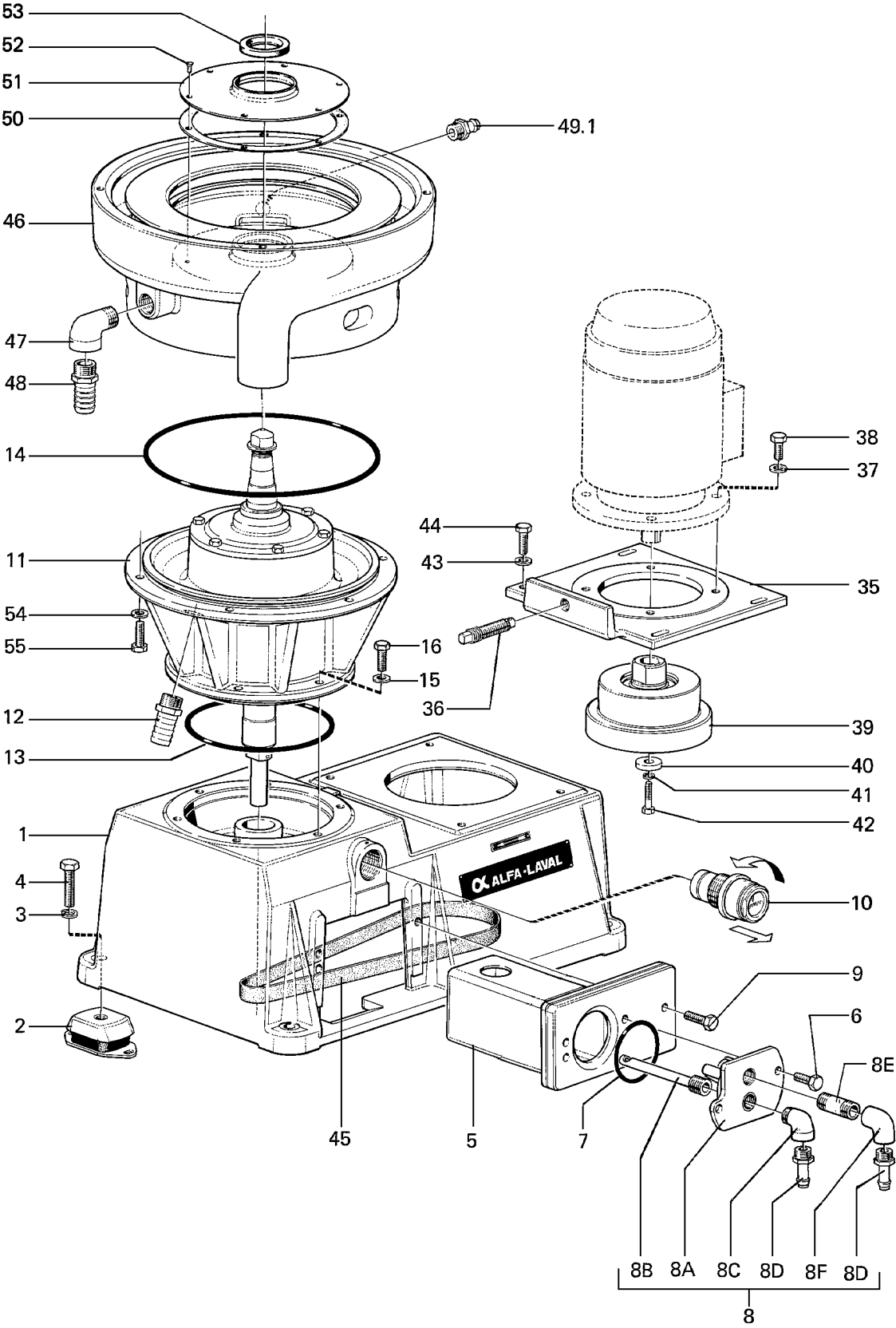

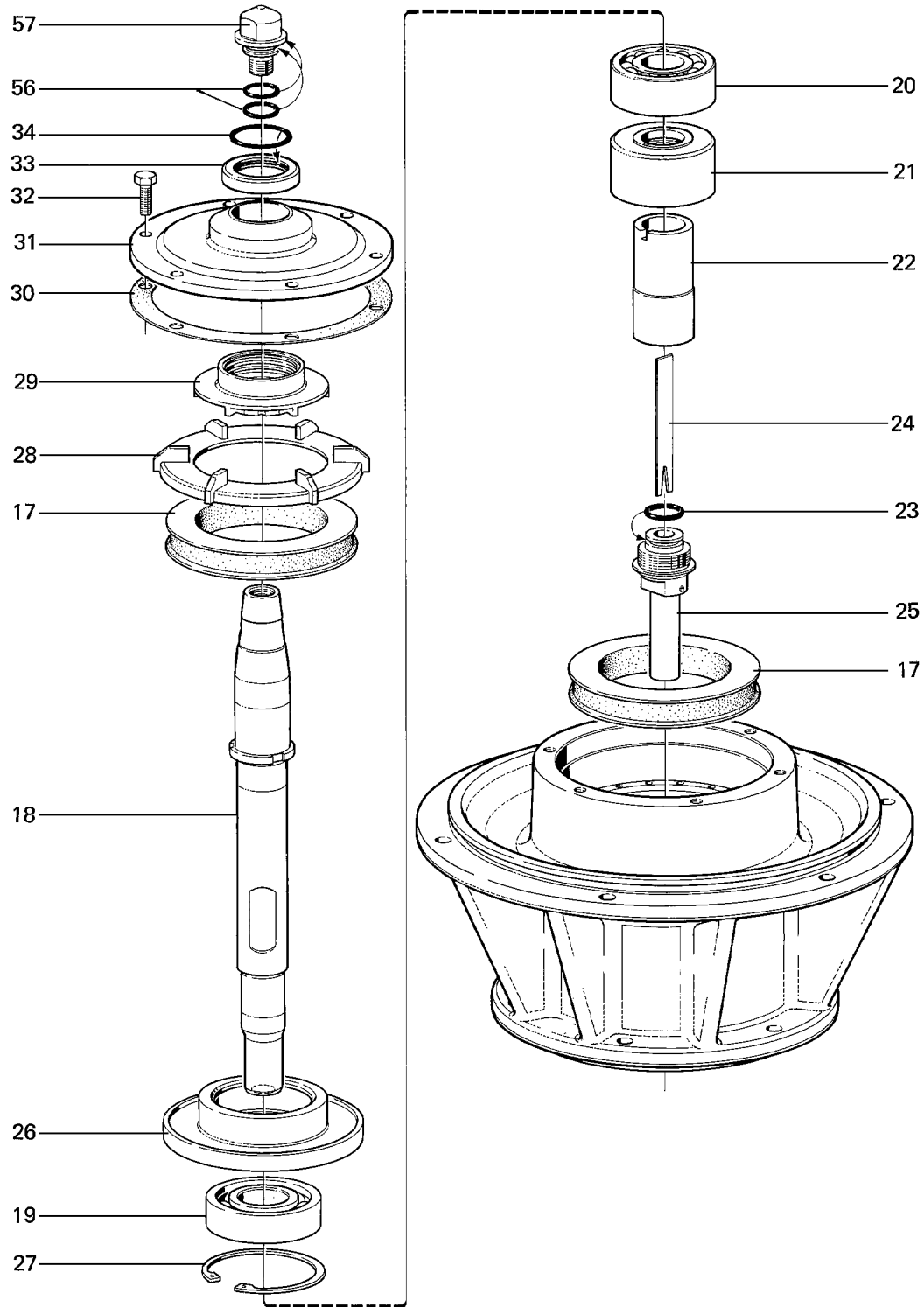

Ref	Part No	Description	Machine unit number or Subassembly description			Notes
			548009-			
			-06	-07	-08	
			Quantity			
		50 Hz	↓			
		60 Hz		↓		
		60 Hz intended for NEMA standard			↓	
50	543662 01	Gasket	1	1	1	
51	543645 01	Screen	1	1	1	
52	260244 01	Screw	6	6	6	
53	73547	Seal ring	1	1	1	
54	548152 03	Washer	6	6	6	
55	221040 05	Screw	6	6	6	
56	223404 82	O-ring	2	2	2	
57	546057 02	Cap nut	1	1	1	

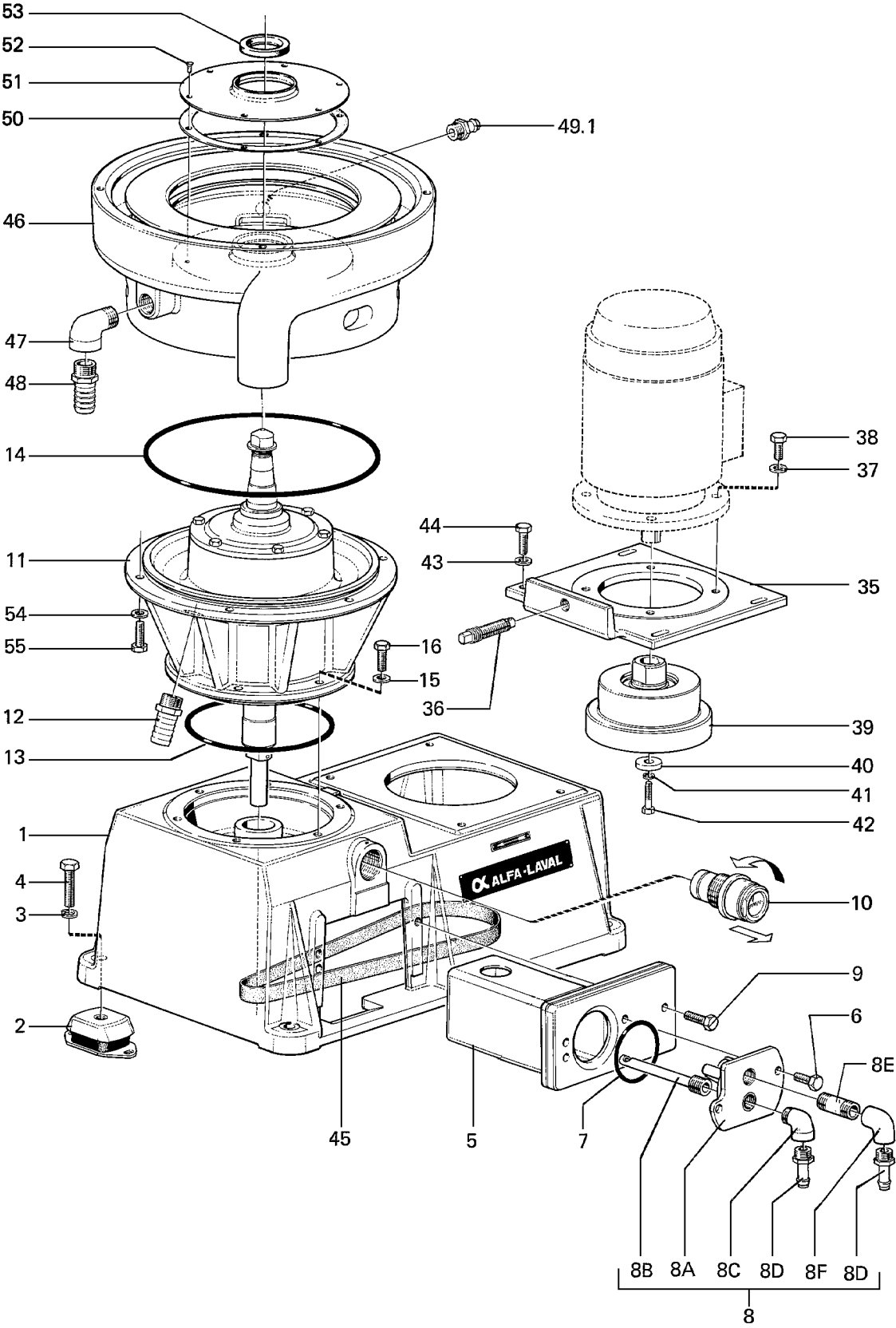

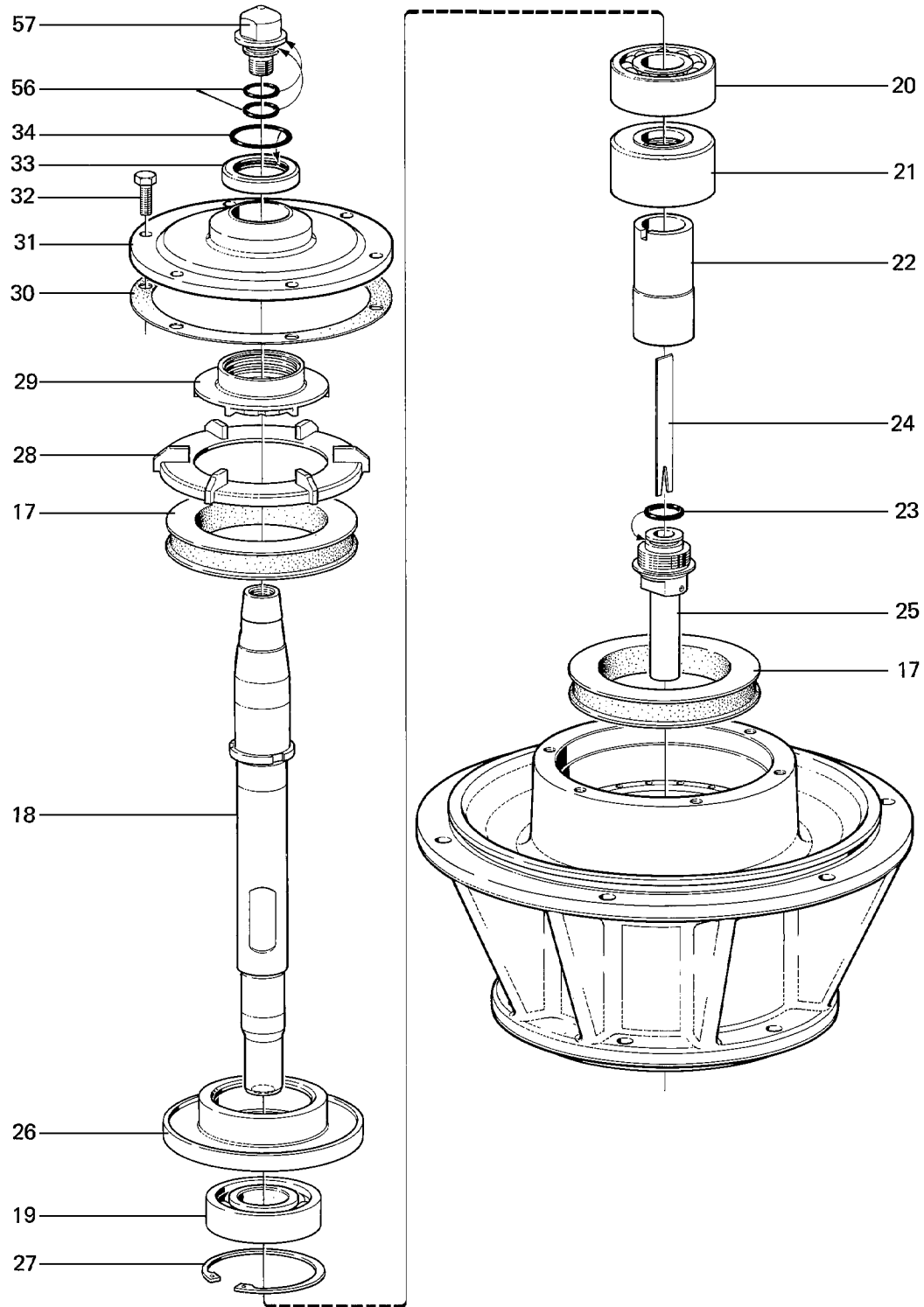

2.1 Oil filling device

Ref	Part No	Description	Machine unit number or Subassembly description							Notes
			545831-							
			-80	Quantity						
1	545817 01	Sleeve	1							
2	223406 27	O-ring	1							
3	223406 27	O-ring	1							
4	544024 01	Nipple	1							
5	542392 02	Seal ring	1							
6	545818 01	Round wire retaining ring	1							
7	545819 01	Oil glass	1							
8	545832 01	Plate	1							

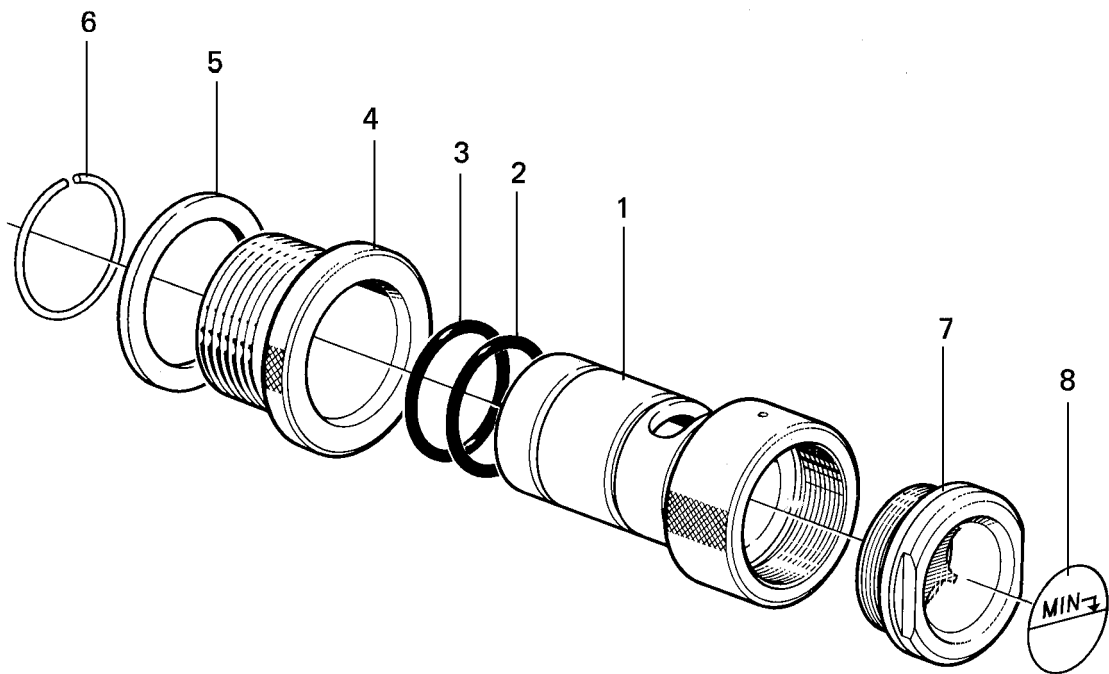

2.2 Belt tightener

Ref	Part No	Description	Machine unit number or Subassembly description		Notes
			-80	-81	
		50 / 60 Hz 60 Hz, NEMA	↓	↓	
1	545848 01	Shaft	1		
1	545848 02	Shaft		1	
2	226314 11	Spring	10	10	
3	545853 01	Sleeve	1		
3	545853 02	Sleeve		1	
4	546562 01	Conveyor	1	1	
5	222119 51	Tubular spring pin	1	1	

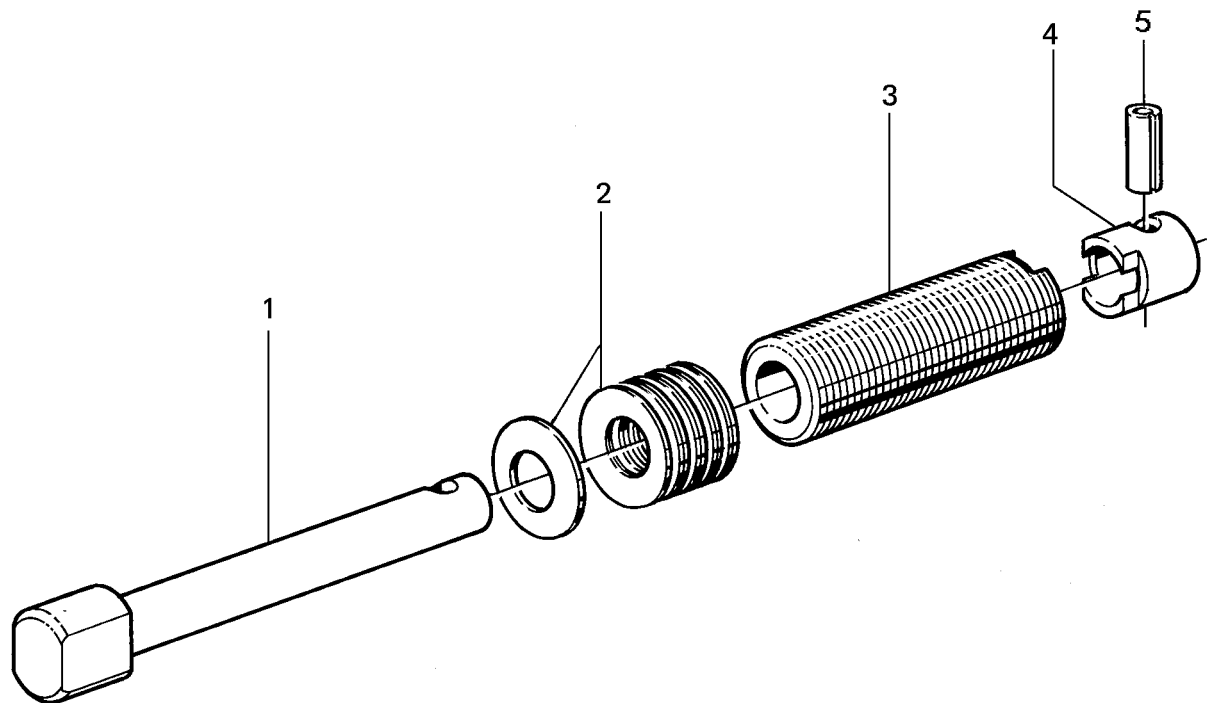

2.3 Friction coupling

Ref	Part No	Description	Machine unit number or Subassembly description		Quantity							Notes	
			-80	-81									
		50 Hz	↓										
		60 Hz		↓									
1	543858 02	Belt pulley			1								
1	543858 04	Belt pulley	1										
2	233211 66	Ball bearing	2	2									
3	542986 04	Washer	1	1									
4	223642 34	Snap ring	1	1									
5	544058 02	Coupling nave			1								
5	546915 02	Coupling nave	1										
6	223641 17	Snap ring	2	2									
7	544060 01	Friction element	4	2									
8	543857 01	Cover	1	1									

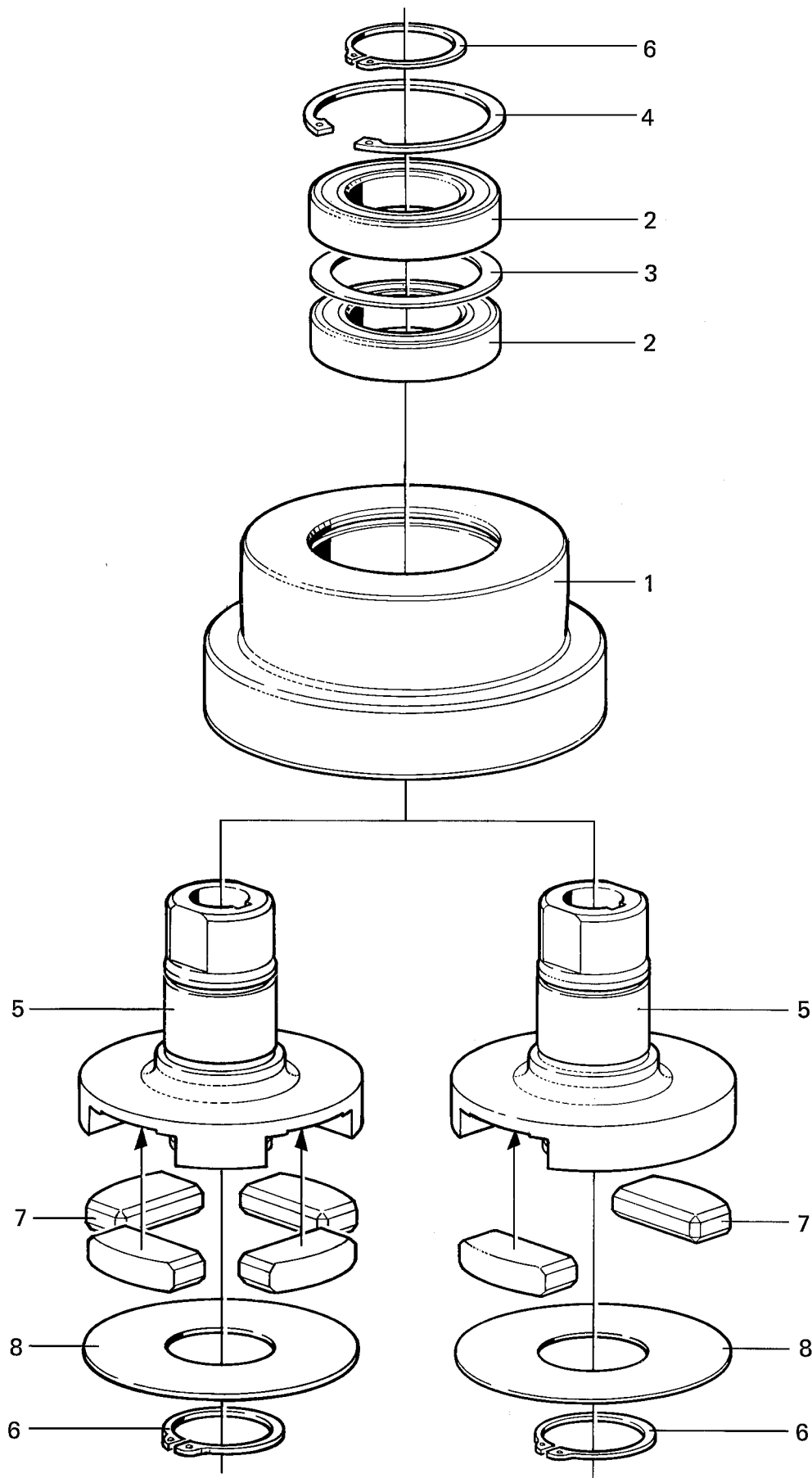

3 Separator bowl

With caulks 0,5 mm

Ref	Part No	Description	Machine unit number or Subassembly description							Notes	
			544458-								
			-01	Quantity							
1	543658 80	Bowl body	1								
1 A	545869 01	Nozzle Ø 1,2 mm	2								
2	223406 35	O-ring	1								
3	68011	O-ring	1								
4	545800 02	Rectangular ring	1								
5	545655 02	Distributing ring lower	1								
6	545800 03	Rectangular ring	1								
7	545871 01	Valve plug	3								
8	545654 02	Operating slide	1								
9	260104 91	O-ring	2								
10	545800 01	Rectangular ring	1								
11	73632	O-ring	1								
12	547152 80	Distributing ring upper	1								
12	548015 80	Distributing ring upper	1								
12 A	222111 70	Cylindrical pin	1								
12 B	222111 95	Cylindrical pin	1								
13	543446 02	Rectangular ring	1								
14	543567 01	Sliding bowl bottom	1								
15	545657 80	Distributor	1								
15 A	545684 01	Distributor	1								
15 B	543590 06	Parallel pin	6								
16	543588 80	Bowl disc	32								
17	544711 80	Wing insert	1								
18	543588 80	Bowl disc	31								
19	543588 80	Bowl disc	1								
20	544925 01	Top disc	1								
21	541691 01	Seal ring	1								
22	543566 01	Bowl hood	1								
23	223406 22	O-ring	1								
24	545797 02	Paring chamber cover	1								
25	223406 14	O-ring	2								
26	545801 02	Leader cone	1								
27	545795 02	Gravity disc	1								
27.1	545795 03	Gravity disc	1								Alternative
27.2	545795 04	Gravity disc	1								Alternative
27.3	545795 05	Gravity disc	1								Alternative
27.4	545795 06	Gravity disc	1								Alternative
27.5	545795 07	Gravity disc	1								Alternative
27.6	545795 08	Gravity disc	1								Alternative
28	545787 01	Heavy phase cover	1								
29	543568 02	Lock ring	1								

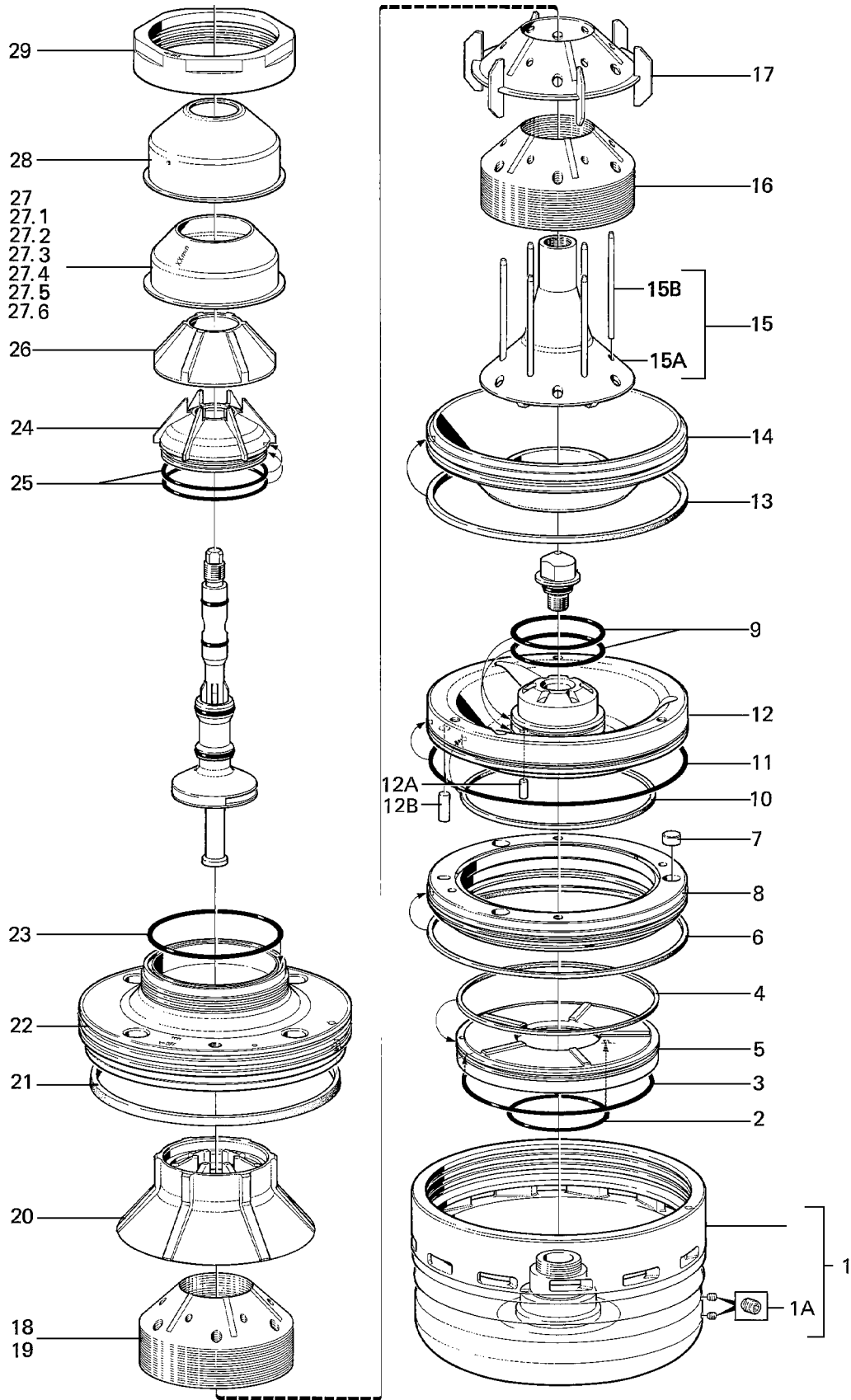

4 Frame hood with inlet and outlet

Ref	Part No	Description	Machine unit number or Subassembly description							Notes
			544468-							
			-01	Quantity						
1	545888 80	Inlet pipe with paring disc	1							
2	74067	O-ring	2							
3	223412 54	O-ring	1							
4	545707 02	Frame hood	1							
5	548152 03	Washer	2							
6	221040 05	Screw	2							
7	543663 01	Height adjusting ring	5							
8	545709 02	Connecting housing	1							
9	223406 35	O-ring	1							
10	544012 02	Insert	1							
11	260244 01	Screw	3							
12	548152 03	Washer	3							
13	221040 05	Screw	3							
14	223404 20	O-ring	2							
15	223406 30	O-ring	2							
16	545710 02	Inlet and outlet housing	2							
17	545765 01	Nut	1							
18	545926 81	Safety device	1							
18 A	545687 80	Safety device	1							
18 AA	545687 02	Safety device	1							
18 AB	544072 01	Bushing	1							
18 AC	544386 01	Gasket	1							
18 B	528920 02	Hose nipple	1							
19	221035 02	Screw	1							
20	546157 80	Lifting eye	2							

4 Frame hood with inlet and outlet

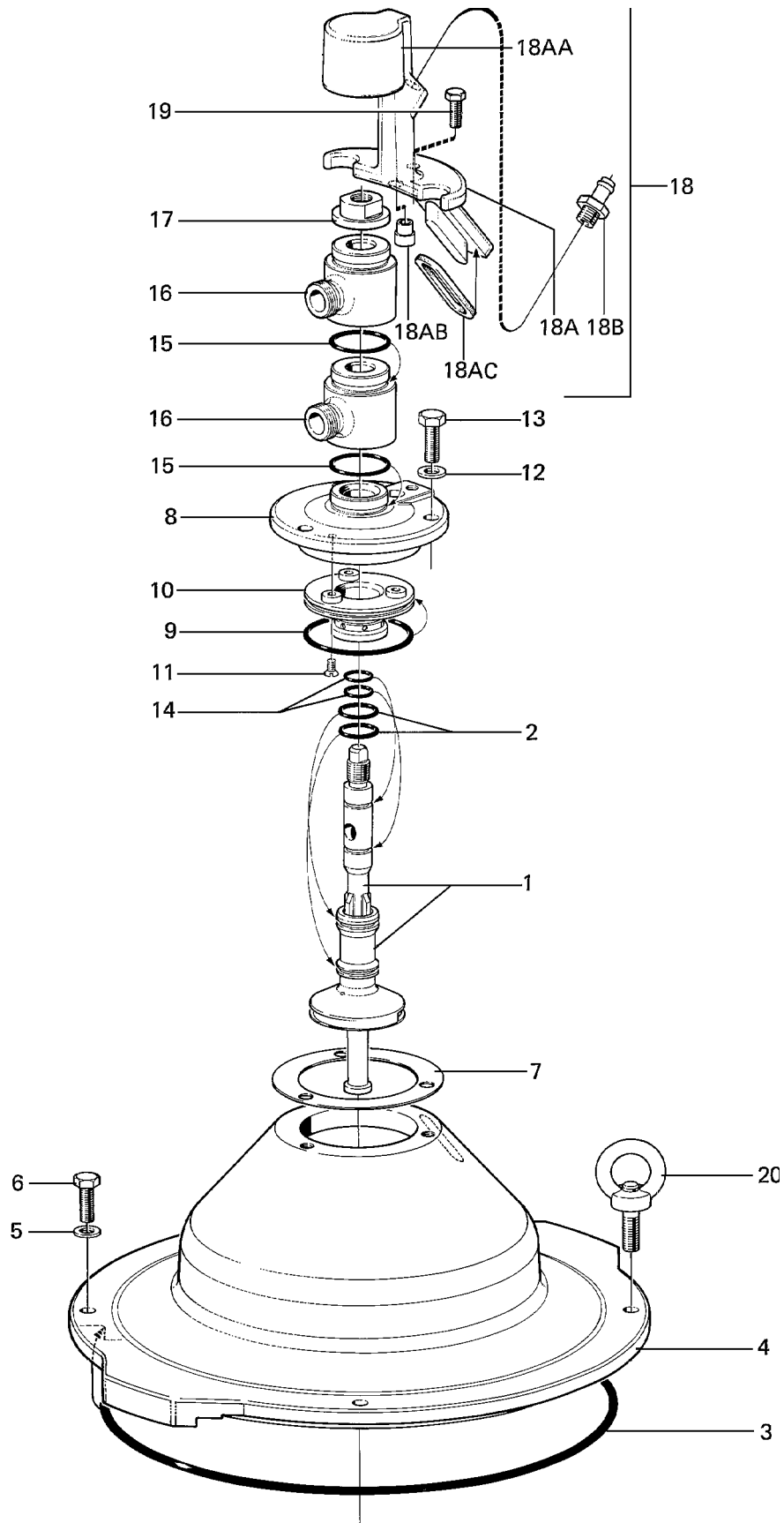

5 Parts for mounting of motor 60 Hz

NEMA standard (type 182TC "C-flange")

Ref	Part No	Description	Machine unit number or Subassembly description						Notes	
			-02	547255-						
			Quantity							
1	547251 02	Motor adapter	1							
2	547260 01	Screw	4							
3	544575 84	Friction coupling	1							See page 32
4	543669 01	Washer	1							
5	70915	Spring washer	1							
6	221035 08	Screw	1							
7	545856 81	Belt tightener	1							See page 22
8	41456	Washer	4							
9	221040 05	Screw	4							
10	260169 23	Flat belt	1							

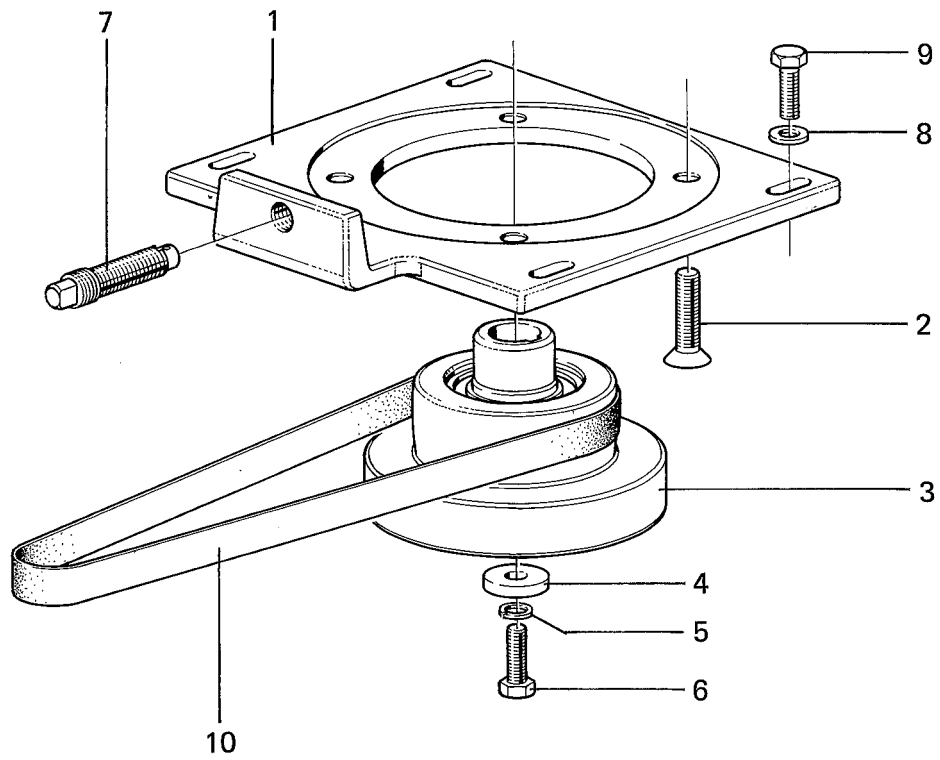

5.1 Friction coupling

Ref	Part No	Description	Machine unit number or Subassembly description							Notes	
			544575-								
			-84	Quantity							
1	543858 02	Belt pulley	1								
2	233211 66	Ball bearing	2								
3	542986 04	Washer	1								
4	223642 34	Snap ring	1								
5	544058 04	Coupling hub	1								
6	223641 17	Snap ring	2								
7	544060 01	Friction element	2								
8	543857 01	Cover	1								

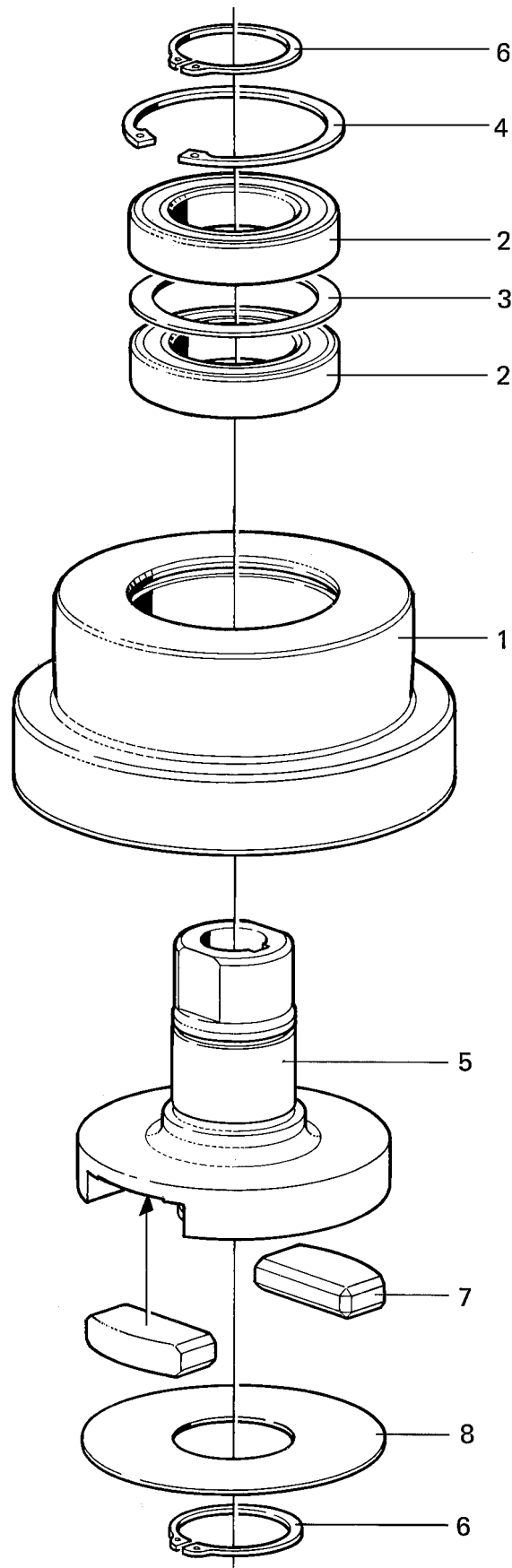





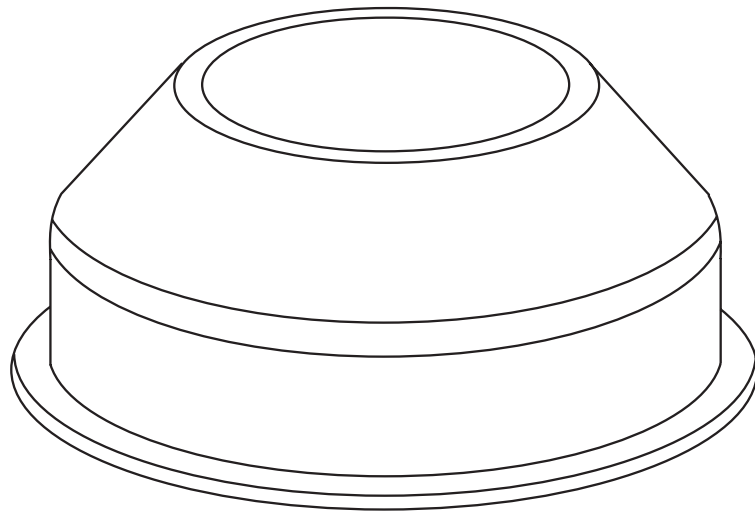

6 Gravity disc for clarification

Ref	Part No	Description	Machine unit number or Subassembly description 545795- -09	Notes
	545795 09	Gravity disc	Quantity 1	

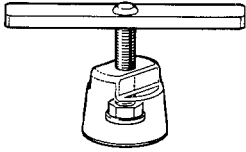
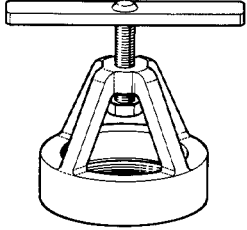
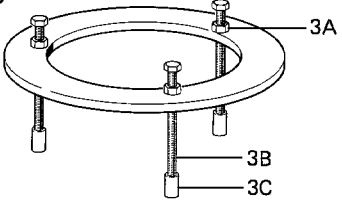
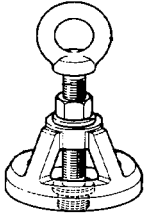

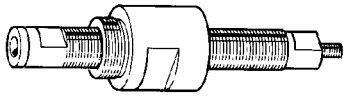
7 Set of tools

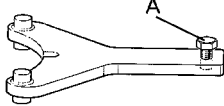
Ref	Part No	Description	Machine unit number or Subassembly description							Notes
			546166-							
			-01	Quantity						
1	545840 80	Puller and lifting tool	1							Bowl body
2	545841 80	Puller and lifting tool	1							Sliding bowl bottom
3	546293 80	Puller	1							Distributing ring upper
3 A	27345	Nut	3							
3 B	221035 60	Screw	3							
3 C	546222 01	Hose	3							
4	548806 80	Compression tool	1							Disc stack
5	221035 60	Screw	2							Operating slide/Distributing ring
6	545844 80	Mounting and dismounting tool	1							Friction coupling
7	544555 01	Mounting tool	1							Ball bearing
8	545867 80	Spanner for bowl hood	1							Bowl hood
8 A	221040 04	Screw	1							
9	545837 02	Spanner for lock ring	1							Lock ring
10	527355 03	Hexagon socket head key	1							Nozzle
11	527380 07	Spanners double	1							
12	526378 19	Open-ended spanner	1							
13	527380 08	Open-ended spanner	1							
14	528927 01	Tin hammer 3 kg	1							
15	527380 06	Open-ended spanner	1							

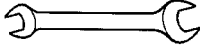
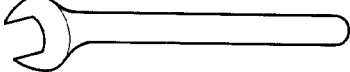
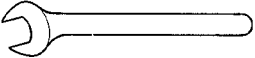
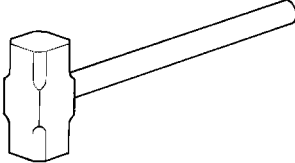
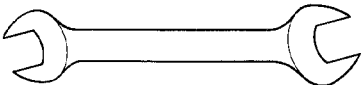
<p>1</p> 	<p>2</p> 	<p>3</p> 
<p>4</p> 	<p>5</p> 	<p>6</p> 
<p>7</p> 	<p>8</p> 	<p>9</p> 
<p>10</p> 	<p>11</p> 	<p>12</p> 
<p>13</p> 	<p>14</p> 	<p>15</p> 

8 Intermediate service kit

Ref	Part No	Description	Machine unit number or Subassembly description						Notes
			546669-						
			-04	Quantity					
2	545800 01	Rectangular ring	1						Distributing ring upper
3	545800 02	Rectangular ring	1						Distributing ring lower
4	545800 03	Rectangular ring	1						Operating slide
5	543446 02	Rectangular ring	1						Sliding bowl bottom/ Bowl body
6	223404 20	O-ring	2						Inlet pipe/ Connecting housing
7	223404 82	O-ring	2						Cap nut
8	223406 14	O-ring	2						Leader cone/ Top disc
9	260104 91	O-ring	2						Distributing ring upper
10	541691 01	Seal ring	1						Bowl hood
12	545871 01	Valve plug	3						Operating slide
15	537086 03	Molybdenum disulfide past	1						
16	539474 03	Silicone grease	1						
17	73632	O-ring	1						Distributing ring upper
18	68011	O-ring	1						Bowl body/ Distributing ring
19	74067	O-ring	1						Inlet pipe/ Insert
20	74067	O-ring	1						Inlet pipe/ Connecting housing
21	223406 22	O-ring	1						Bowl hood/ Gravity disc
22	223406 35	O-ring	1						Insert/ Connecting housing
23	223406 35	O-ring	1						Bowl body/ Distributing ring

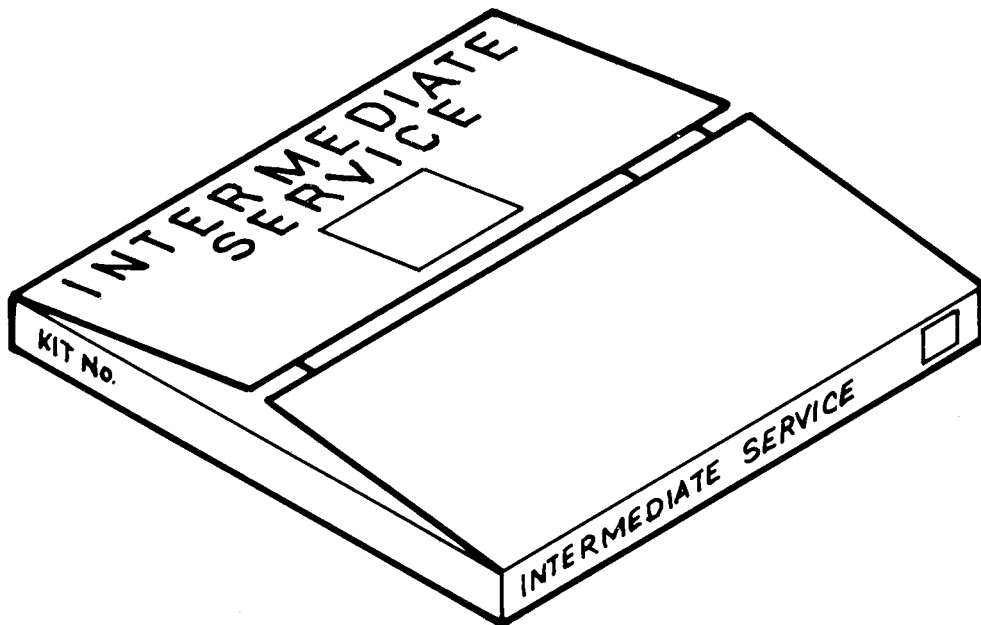

9 Major service kit

Ref	Part No	Description	Machine unit number or Subassembly description 546670-							Notes
			-01 -02		Quantity					
		50 Hz	↓							
		60 Hz		↓						
5	223406 25	O-ring	1	1						Pump sleeve/ Belt pulley
6	223406 29	O-ring	1	1						Deflector ring/ Bowl spindle
7	223406 30	O-ring	2	2						Outlet housing
10	223412 49	O-ring	1	1						Frame intermediate/ Top part
11	73547	Seal ring	1	1						Frame top part Bowl spindle
12	37535	Ball bearing	1	1						Frame intermediate part/ Bowl spindle
13	548051 05	Ball bearing	1	1						Ball bearing holder/ Bowl spindle
14	544060 01	Friction element	4	2						Friction coupling
15	543612 01	Gasket	1	1						Frame intermediate part/ Top bearing cover
16	260169 22	Flat belt	1							
16	260169 23	Flat belt		1						
17	543619 80	Rubber buffer	2	2						Frame intermediate part/ Ball bearing holder
18	544465 02	Locking liquid	1	1						

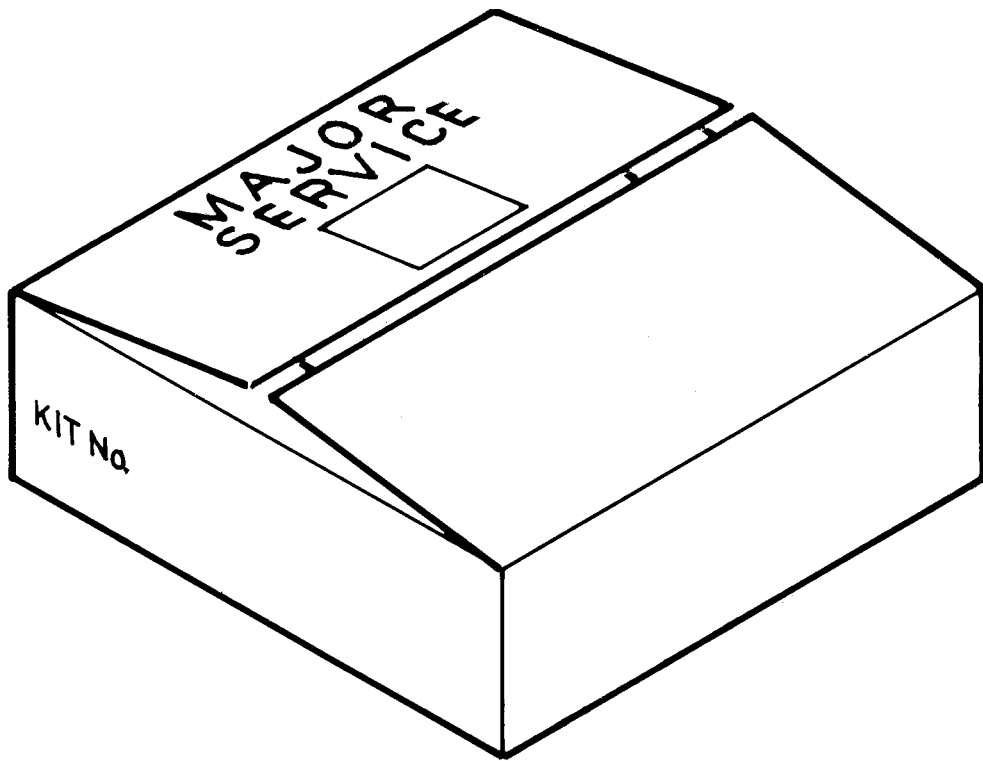

10 Tool box

Ref	Part No	Description	Machine unit number or Subassembly description 558533- -81	Notes
			Quantity	
7	558533 10	Padlock	1	

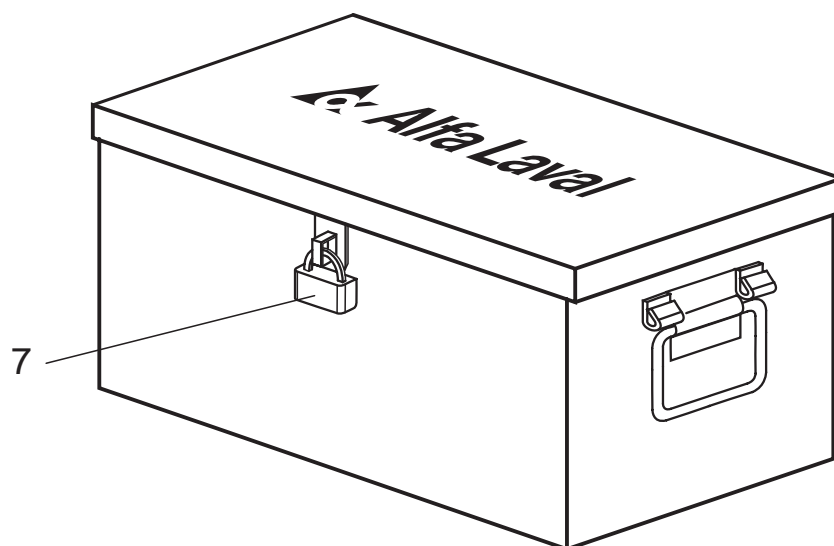

11 Cross reference list

Part No	Page	Ref.
27345	36	3 A
37535	40	12
37535	12	20
41456	30	8
68011	26	3
68011	38	18
68956	12	12
68956	12	48
70915	30	5
70915	12	41
73547	40	11
73547	16	53
73632	26	11
73632	38	17
74067	28	2
74067	38	19
74067	38	20
221035 02	28	19
221035 02	12	32
221035 08	30	6
221035 08	12	42
221035 12	12	42
221035 60	36	3 B
221035 60	36	5
221040 04	36	8 A
221040 05	28	6
221040 05	30	9
221040 05	28	13
221040 05	12	16
221040 05	12	44
221040 05	16	55
221040 25	12	6
221040 25	12	9
221040 52	12	38
221045 29	12	4
222111 70	26	12 A
222111 95	26	12 B
222119 51	22	5
223107 35	12	3
223404 20	38	6
223404 20	28	14
223404 82	38	7
223404 82	16	56
223406 14	38	8
223406 14	26	25
223406 22	38	21
223406 22	26	23
223406 25	40	5
223406 25	12	23
223406 27	20	2

Part No	Page	Ref.
223406 27	20	3
223406 29	40	6
223406 29	12	34
223406 30	40	7
223406 30	28	15
223406 35	26	2
223406 35	28	9
223406 35	38	22
223406 35	38	23
223412 38	12	13
223412 49	40	10
223412 49	12	14
223412 54	28	3
223641 17	24	6
223641 17	32	6
223642 34	24	4
223642 34	32	4
223642 36	12	27
226314 11	22	2
233211 66	24	2
233211 66	32	2
260104 91	26	9
260104 91	38	9
260169 22	40	16
260169 22	12	45
260169 23	30	10
260169 23	40	16
260169 23	12	45
260244 01	28	11
260244 01	16	52
526371 03	12	8 F
526378 19	36	12
527355 03	36	10
527380 06	36	15
527380 07	36	11
527380 08	36	13
528920 02	28	18 B
528920 04	12	8 D
528920 04	12	49.1
528927 01	36	14
537086 03	38	15
539418 03	12	47
539418 05	12	8 C
539474 03	38	16
541691 01	38	10
541691 01	26	21
542392 02	20	5
542986 04	24	3
542986 04	32	3
543446 02	38	5

Part No	Page	Ref.
543446 02	26	13
543566 01	26	22
543567 01	26	14
543568 02	26	29
543588 80	26	16
543588 80	26	18
543588 80	26	19
543590 06	26	15 B
543609 02	12	26
543612 01	40	15
543612 01	12	30
543613 02	12	31
543619 80	12	17
543619 80	40	17
543645 01	16	51
543658 80	26	1
543662 01	16	50
543663 01	28	7
543669 01	30	4
543669 01	12	40
543857 01	24	8
543857 01	32	8
543858 02	24	1
543858 02	32	1
543858 04	24	1
544012 02	28	10
544024 01	20	4
544058 02	24	5
544058 04	32	5
544060 01	24	7
544060 01	32	7
544060 01	40	14
544072 01	28	18 AB
544203 02	12	29
544337 02	12	33
544386 01	28	18 AC
544465 02	40	18
544555 01	36	7
544575 80	12	39
544575 81	12	39
544575 84	30	3
544711 80	26	17
544923 02	12	46
544925 01	26	20
545596 01	12	22
545597 01	12	24
545599 80	12	25
545600 01	12	18
545601 80	12	21
545620 02	12	28

Part No	Page	Ref.
545654 02	26	8
545655 02	26	5
545657 80	26	15
545684 01	26	15 A
545687 02	28	18 AA
545687 80	28	18 A
545707 02	28	4
545709 02	28	8
545710 02	28	16
545735 02	12	5
545765 01	28	17
545782 02	12	35
545787 01	26	28
545795 02	26	27
545795 03	26	27.1
545795 04	26	27.2
545795 05	26	27.3
545795 06	26	27.4
545795 07	26	27.5
545795 08	26	27.6
545795 09	34	
545797 02	26	24
545800 01	38	2
545800 01	26	10
545800 02	38	3
545800 02	26	4
545800 03	38	4
545800 03	26	6
545801 02	26	26
545817 01	20	1
545818 01	20	6
545819 01	20	7
545831 80	12	10
545832 01	20	8
545837 02	36	9
545840 80	36	1
545841 80	36	2
545844 80	36	6
545848 01	22	1
545848 02	22	1
545853 01	22	3
545853 02	22	3
545856 80	12	36
545856 81	12	36
545856 81	30	7
545867 80	36	8
545869 01	26	1 A
545871 01	26	7
545871 01	38	12
545888 80	28	1

Part No	Page	Ref.
545892 01	12	2
545926 81	28	18
546057 02	16	57
546157 80	28	20
546222 01	36	3 C
546293 80	36	3
546562 01	22	4
546563 01	12	7
546915 02	24	5
547152 80	26	12
547251 02	30	1
547260 01	30	2
548010 02	12	1
548012 02	12	11
548015 80	26	12
548051 05	40	13
548051 05	12	19
548152 03	28	5
548152 03	28	12
548152 03	12	15
548152 03	12	37
548152 03	12	43
548152 03	16	54
548494 80	12	8 A
548543 80	12	8 B
548550 80	12	8
548612 01	12	8 E
548806 80	36	4
558533 10	42	7