



PureBilge

Oily water cleaning system



PureBilge oily water cleaning system

Towards cleaner oceans

Bilge water generated onboard ships is a major environmental concern for the shipping industry. Regardless of its source, bilge water must be treated to reduce the oil content to levels that meet international regulations for release into the environment. This is critical to keeping the world's oceans and their vast marine ecosystems healthy and productive.

The impact of ship propulsion on the marine environment can be minimized, heavy fines avoided and the work load of the crew significantly reduced, if efficient bilge water treatment is carried out onboard. The need for waste disposal ashore can also be reduced. Over the years, the cost for waste disposal has increased as local authorities enforce stricter laws for land-based companies that process this waste. This translates into higher operating costs.

Application

Cleaning bilge water poses distinct challenges. Not only does the composition and flow of bilge water change, making continuous and efficient treatment difficult, but treatment onboard presents another set of constraints.

Treatment methods must meet individual ship requirements and demands for safety, reliability, compactness, automation, low maintenance and the ability to withstand rough weather conditions. These requirements must be met without reducing the performance of the treatment system.

Centrifugal separation has proven to be the most reliable, efficient and flexible method for continuous removal of oil and other contaminants suspended in the bilge water onboard ships and at land-based power plants.

Capacities

PureBilge is available in two standard versions:

- PureBilge 2515: 2 500 l/h, 15 pp
- PureBilge 2505: 2 500 l/h, 5 ppm
- PureBilge 5015: 5 000 l/h, 15 ppm
- PureBilge 5005: 5 000 l/h, 5 ppm

PureBilge: Reliable, efficient, continuous

The Alfa Laval PureBilge solution is a reliable single-stage centrifugal separation system for the highly efficient treatment of large bilge water volumes at sea as well as ashore. The compact modular system reduces the level of contaminants in bilge water to between 0 and 5 ppm oil in water.

Based on a standardized concept, PureBilge is a complete stand-alone system that is easy to install for any new or existing installation. Continuous, fully automatic operation – even when subjected to oil shock and rough weather conditions – reduces the need for large bilge water holding tanks. This increases payload capacity.

PureBilge significantly reduces operating costs compared to conventional bilge water systems thanks to the reduced volumes of waste that require disposal.

PureBilge complies with the Marine Environment Protection Committee Resolution, MEPC.107(49), of the International Maritime Organization (IMO) and USCG regulation (46 CFR 106.050).

Benefits for shipyards

- **Compact, modular, easy-to-install system** saves time, space and money.
- **Continuous, single-stage operation** requires less holding tank volume and provides more space for payload.
- **Easy integration** with existing communications systems onboard.

Benefits for owners and operators

- **Reduced operating costs** thanks to low maintenance, automated control, minimal waste disposal, no chemical consumption and an absence of filter elements that require replacement as standard.
- **Reliable, always-available system.** Operates continuously with high performance, regardless of variations in feed, oil shocks and rough weather conditions.
- **Easy to operate.** Automated control and monitoring system integrates with existing Alfa Laval systems, providing a single user-friendly interface.
- **Safe operation.** A password-locked switch can be set in manual/locked position to ensure that only the individual responsible for environmental compliance may authorize overboard discharge.

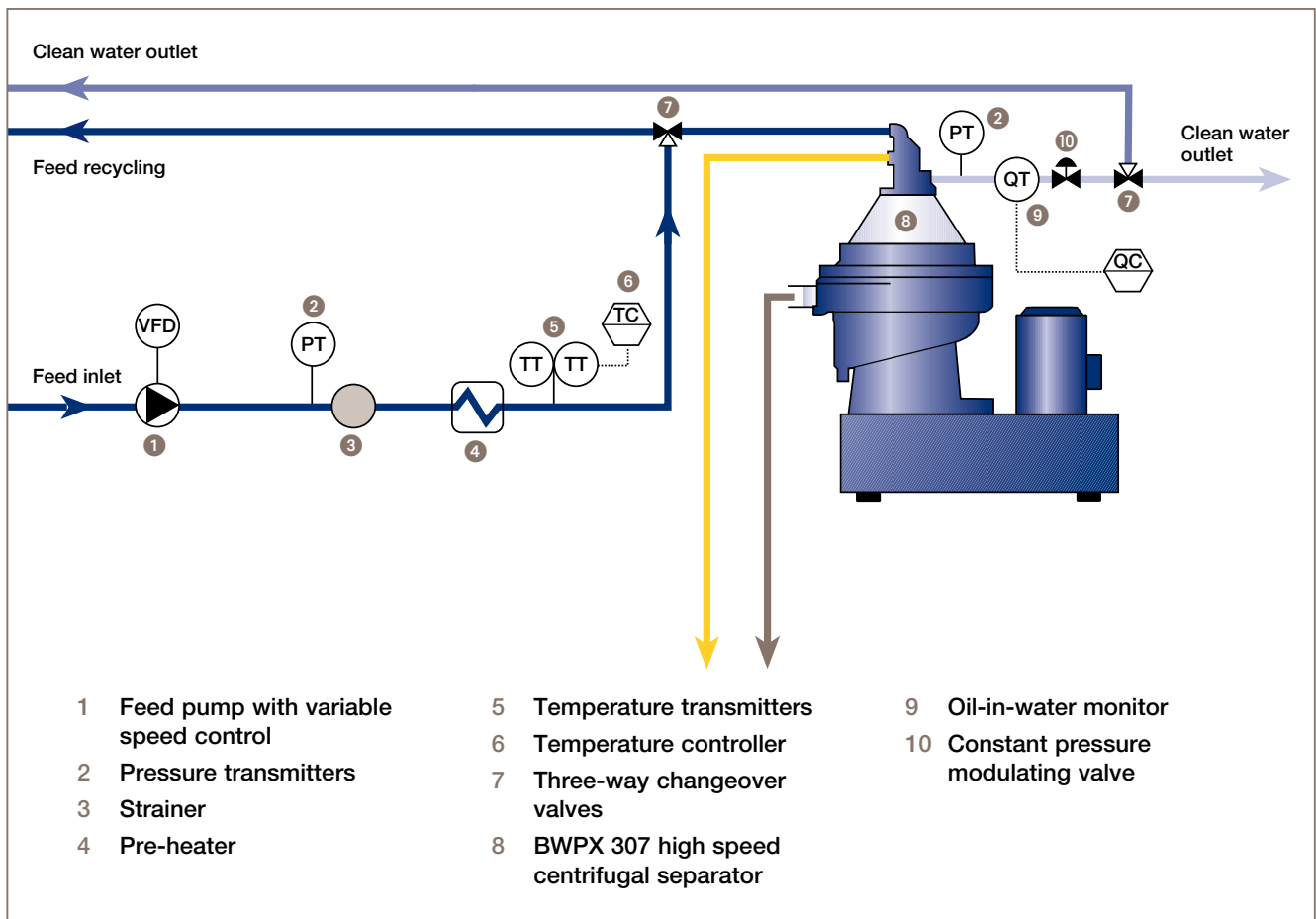

Schematic diagram of PureBilge cleaning system

PureBilge BlueBox Data Recorder

The increasing number of cases where severe penalties have been imposed for discharging bilge water with unacceptably high oil content into the ocean, and falsification of Oil Record Books, is a growing source of concern for shipping companies.

PureBilge BlueBox Data Recorder is a fully automatic, tamper proof bilge data recorder with visuALog software. The system records oil ppm levels, GPS position, separator operation, full alarm log, overboard valve position and overboard flow data.



EPC 60 Bilge process controller



Tamper proof cover on oily water monitor

EPC 60 Bilge process controller

This new generation of the easy-to-operate, computer-based Alfa Laval process controller facilitates advanced fully automated monitoring and control of PureBilge functions by displaying in clear text process parameters, alarms and other data.

The EPC 60 Bilge process controller displays the status of the process, system valves and transmitters, activated or deactivated.

The process controller is based on the same hardware used in other Alfa Laval units, making it easy to use for operators who are already familiar with this equipment.

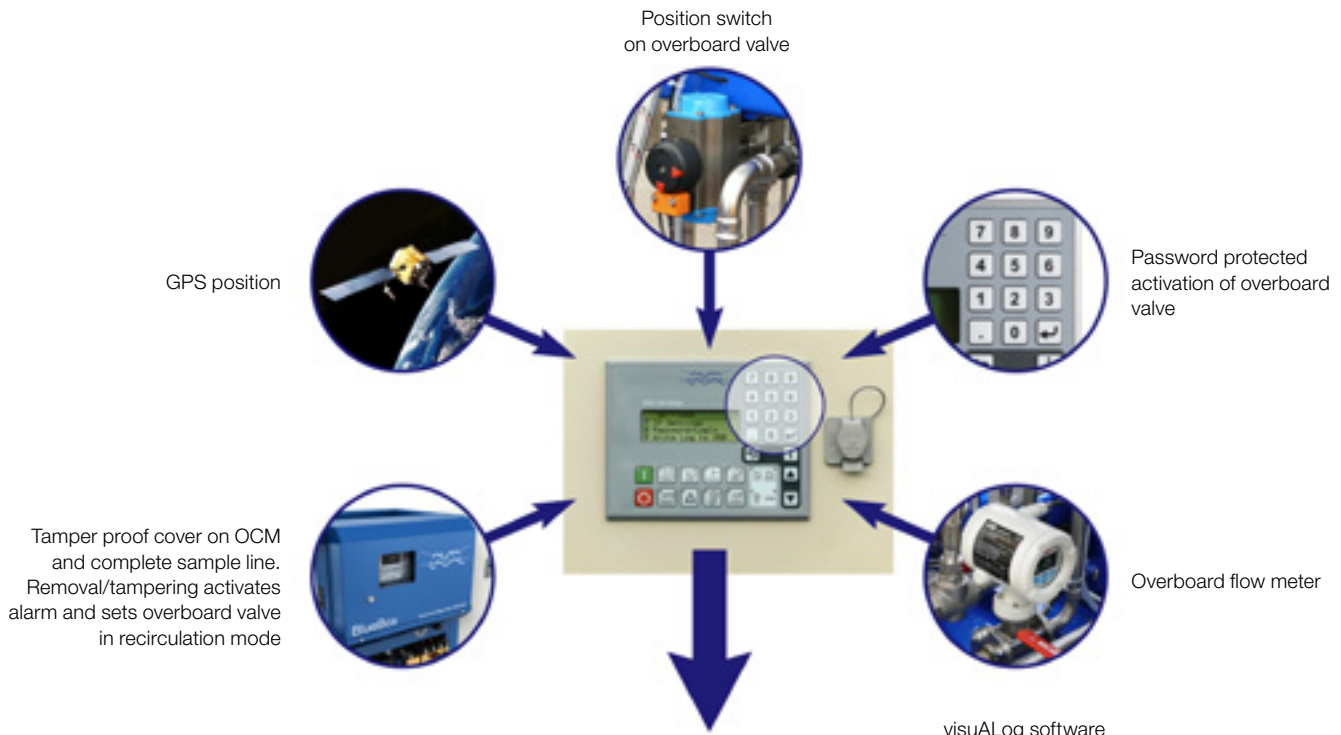

The BlueBox records and the visuALog displays ppm value, GPS position, overboard flow, date and time, full alarm log and the position of the overboard valve

Bilge water

Bilge water can be a mixture of water, fuel oil, lube oil, hydraulic oil, detergents, oil additives, chemicals, catalytic fines, soot and other substances. This mixture is normally collected in a bilge water settling tank and maintained at an elevated temperature.

The marine sector uses large amounts of chemicals for cleaning, service and maintenance activities in the engine room and many of these products are surfactant-based. As such, these chemicals contribute to emulsion formation in a ship's bilge water system. An emulsion is a mixture of oil and water, where small oil droplets are dispersed in the continuous water phase.

Separation efficiency can be compromised by the formation of stable emulsions. This becomes challenging when an emulsion is stabilized by surfactants, water-soluble polymers or colloidal particles. Centrifugal treatment of bilge water using the PureBilge system effectively handles separation.

System description

The PureBilge bilge water treatment system comprises four main functions:

- Forwarding/pumping
- Oily water pre-treatment
- Centrifugal separation
- Process control and monitoring

Oily water is pumped from the settling tank to the pre-treatment stage by a positive displacement pump with variable frequency drive.

In the pre-treatment stage the bilge water is fed through a basket strainer that traps large particles from the fluid. The fluid then passes through a heat exchanger, which raises the temperature of the fluid to the required level for optimal separation efficiency, generally between 60°C to 70°C.

A three-way changeover valve is located after the heat exchanger in the pre-treatment stage. The purpose of this valve is to direct the fluid to the separation stage when all process conditions, such as feed temperature, pressure and separator speed match pre-set values. If any condition is not met, the valve will re-circulate the fluid to the bilge water settling tank.

When all process conditions are fulfilled, the fluid is directed to the separation stage. Fluid then enters a high-speed

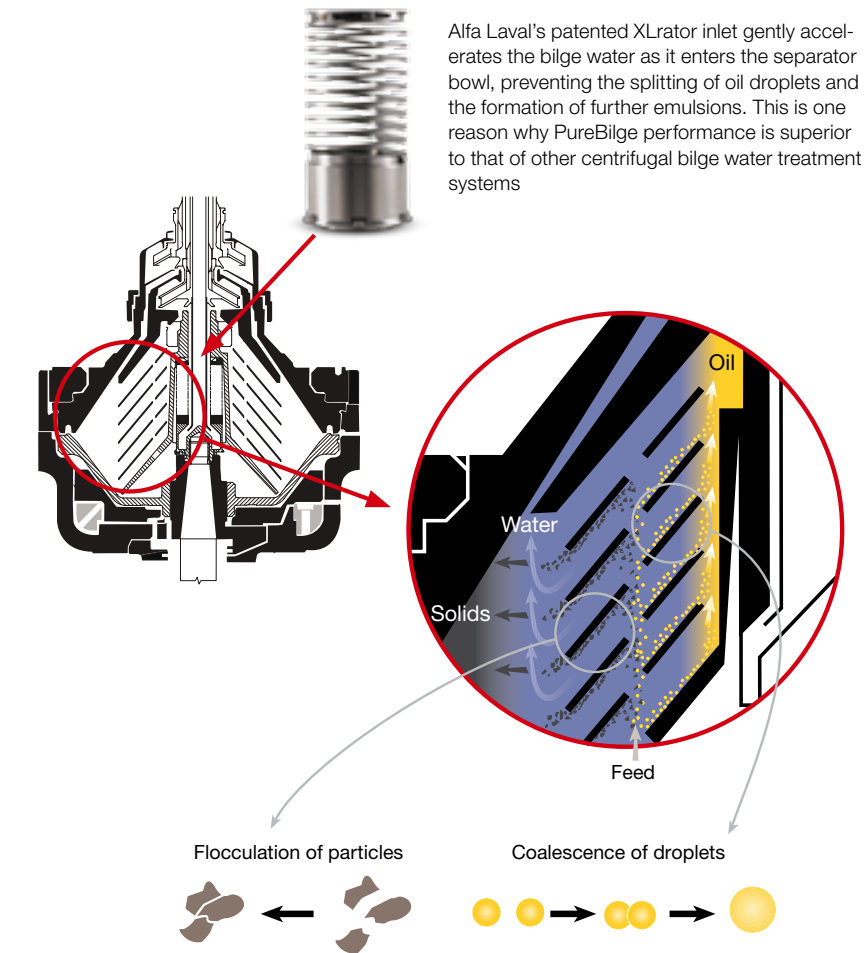

Alfa Laval's patented XLrator inlet gently accelerates the bilge water as it enters the separator bowl, preventing the splitting of oil droplets and the formation of further emulsions. This is one reason why PureBilge performance is superior to that of other centrifugal bilge water treatment systems

centrifugal separator that is designed for continuous, high-efficiency separation of large volumes of bilge water. Oil and emulsions separated from the bilge water are continuously discharged and directed to a sludge or waste-oil collecting tank. Solids are discharged intermittently through the self-cleaning mechanism of the centrifuge.

Treated water is also continuously discharged. An oil-in-water monitor measures the oil content in the treated bilge water in full compliance with IMO Resolution MEPC.107(49). When the oil content is below a pre-set value (15 ppm or lower), the treated water can be directed either to a holding tank for discharge overboard at the ship operator's convenience, or pumped directly overboard. If the oil content is above the pre-set value, the water is re-circulated to the bilge water settling tank.

Revolutionary design features

PureBilge incorporates the Alfa Laval BWPX 307 high-speed centrifuge and the latest achievements in fluid dynamics technology:

- A patented Alfa Laval XLrator inlet device gently accelerates the bilge water into the separator bowl with minimal shearing and foaming. This greatly improves the separation efficiency by preventing droplet splitting and further emulsion formation.
- The disc-stack and bowl design provides the maximum surface area for separation. Specially designed distribution holes and optimized caulk configuration further enhance separation efficiency.

These design features in combination with stable, continuous operation ensure proper handling of oil shocks that generally bring static cleaning systems to a standstill.

Options

- BlueBox Data Recorder
- Sludge removal kit
- Remote operation

Technical data

Power and connections

Supply voltage	Three-phase, 220V up to 690V	
Frequency	50/60 Hz	
Power consumption	12 kW	
Instrument air	G 1/2"	500–800 kPa
Operating water	G 3/4"	200–800 kPa
Cooling water	G 1/2"	200–800 kPa
Oil/water	DN 25	100–400 kPa
Steam	DN 25	700 kPa saturated
Thermal oil	DN 25	300–600 kPa 220 °C max

Net weight

Module complete	1 880 kg
Feed pump skid	150 kg
Dosing pumps skid (without liquid)	40 kg

Dimensions

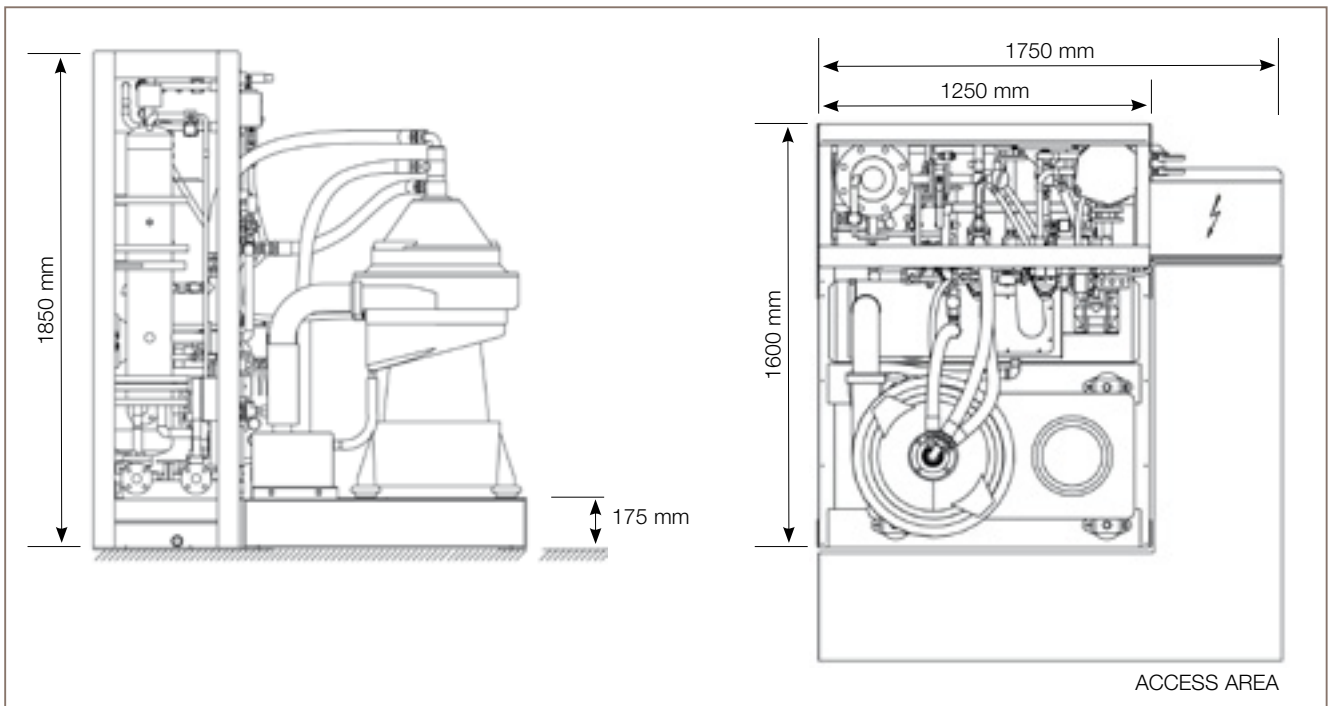

EMD00199EN 1109

Alfa Laval reserves the right to change specifications without prior notification.

How to contact Alfa Laval

Up-to-date Alfa Laval contact details for all countries are always available on our website at www.alfalaval.com